

Featuring an innovative new hydraulic design* and using the latest sealing and guiding technology, this new tool delivers unmatched fastening efficiency and dependability.

*Patent pending

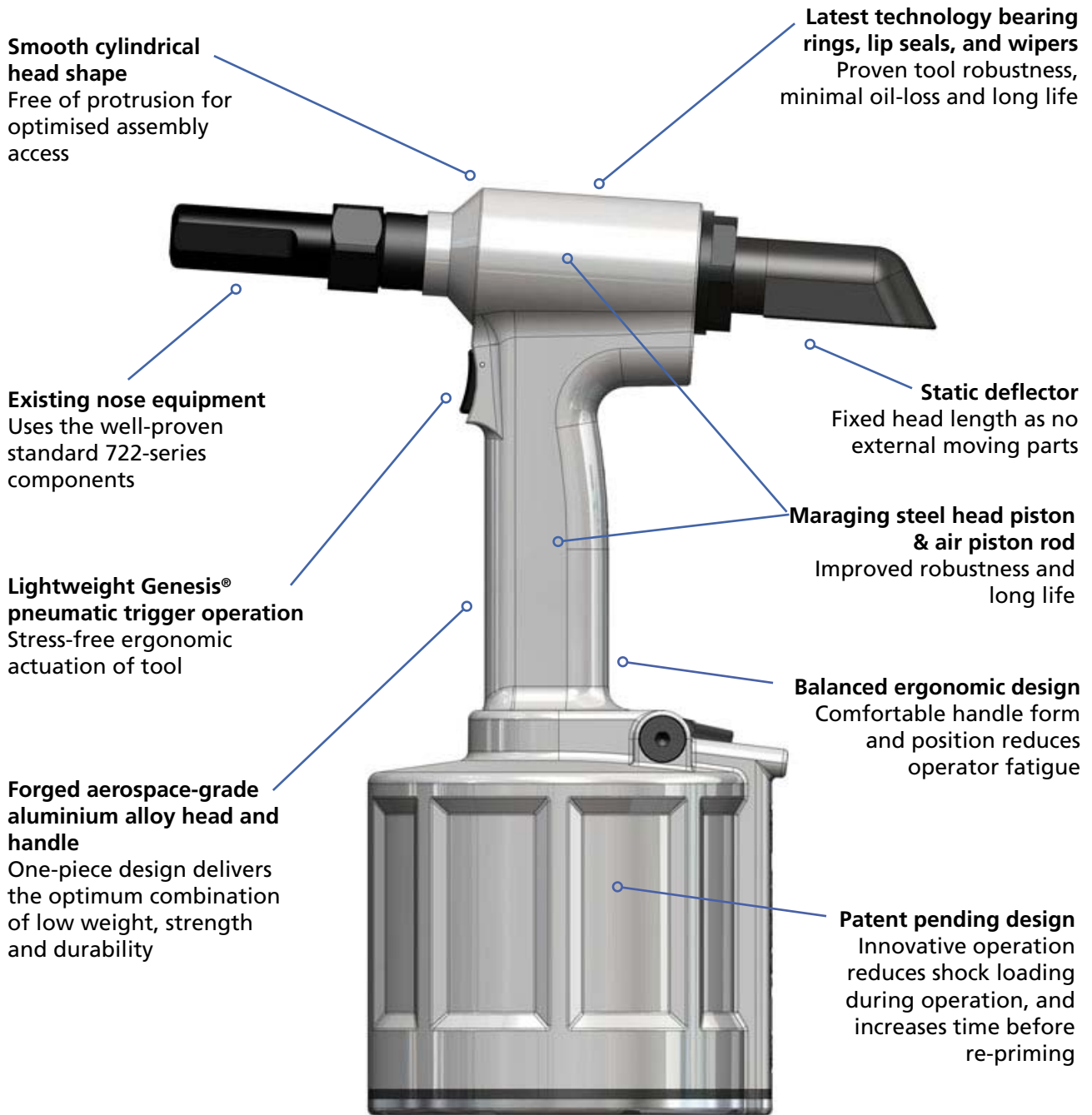



Hydro-pneumatic Handtool for Lockbolts 73200 Model



Specifications

Weight (without nose equipment)	4.9 kg
Pull force (@ 5.5 bar)	28.5 kN
Stroke	21 mm
Cycle time	3 seconds
Noise level	<75 dB(A)
Vibration	<2.5m/s ²

Placing Capability

High pull force and long stroke mean the 73200 tool can install all Avdel® lockbolts up to $\varnothing 3/8"$ (10 mm), all Avbolt® fasteners up to $\varnothing 5/16"$ (8 mm), and Avseal® II sealing plugs up to $\varnothing 16$ mm diameter.

For detailed information on placing capability, required air pressure, and nose equipment please refer to the tool manual on our website www.avdel-global.com or contact your local Avdel representative.

Dimensions

