

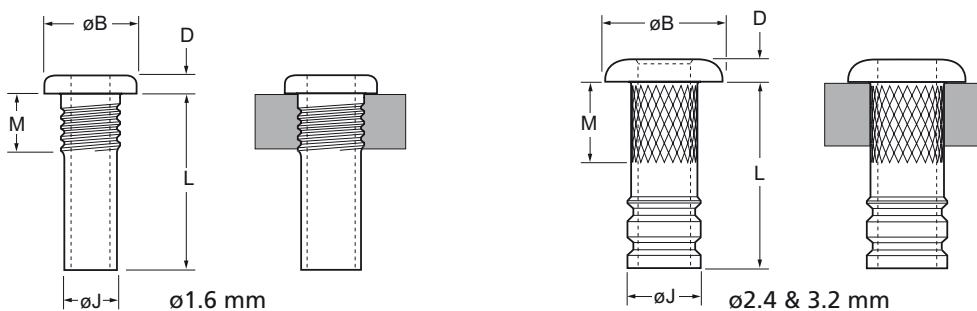

English	Français	Deutsch	Italiano	Español
Dome head	Tête plate	Flachrundkopf	Testa tonda	Cabeza alomada
Brass*	Laiton*	Kupfer-Zink Legierung*	Ottone*	Latón*
Tin plated**	Étamé**	verzinkt**	Stagnato**	Estañado**

*: BS EN 12166 CW 508L DIN 17660 CuZn37

** : We recommend tin plated parts 1107 Series are installed within 9 months from the date they were produced.
 Nous conseillons d'utiliser les pièces en laiton étamé du série 1107 sous un délai de 9 mois après la date de production.
 Wir empfehlen, verzinkte Nieten der Serie 1107 innerhalb 9 Monaten nach Produktionsdatum zu verarbeiten.
 Raccomandare di utilizzare i prodotti stagnati serie 1107 entro 9 mesi a decorrere dalla data di fabbricazione.
 Recomendamos utilizar sus piezas estañadas serie 1107 antes de 9 meses desde la fecha de su fabricación.

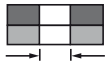

Ø			ØB	D	L	ØJ	M	No. of grooves cannelures Rillen rigature aros	Fasteners per pod Nombre de rivets par chargeur / Niete pro Magazin / Rivetti per caricatore / Uds./carga ± 1	Part No/ref
	nom.	min.								
1.6 (1/16")	1.80	1.93	2.80	0.61	4.11	1.79	2.04	4	62	01107-00205
					6.51					
2.4 (3/32")	2.62	2.74	4.15	0.94	8.36	2.60	3.43	2	33	01107-00310
					9.96			3	28	01107-00312
3.2 (1/8")	3.38	3.51	5.52	1.15	9.96	3.36	3.43	3	26	01107-00412

all dimensions in mm / en millimètres / alle Maße in mm / in millimetri / en milímetros