

# E4 Push-to-Close Latch

Push-to-open · Touch latch · Small

- Concealed latch points
- Door ejection feature
- Snap-in installation

### Material and Finish

Latch and keeper: Acetal, black  
Alignment guide: Acetal, white

### Performance Details

Average tensile load: 15 N (3.5 lbf)

Operating temperature range:  
-40°C (-40°F) to 105°C (220°F)

Flammability rating: UL94-HB

### Installation Notes

Be sure the mounting surface is clean and capable of retaining a satisfactory adhesive bond.

Self-adhesive keepers are designed to function under intermittent break-away loads

### Latch

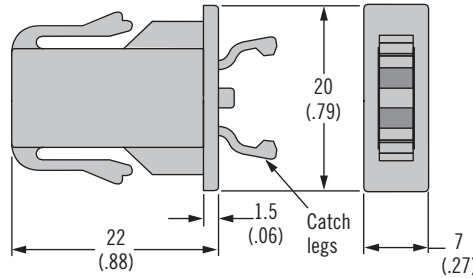

### Keeper Assembly

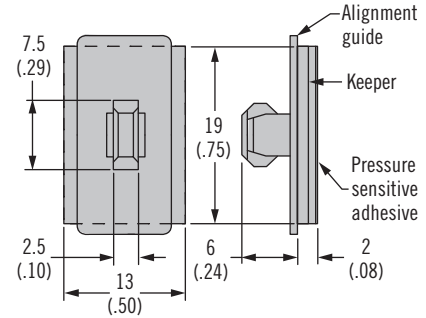

### Spacer

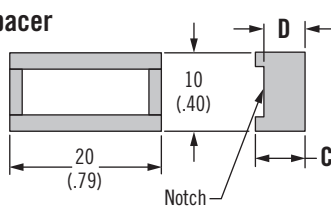

### Unlatched

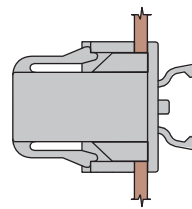

### Latched

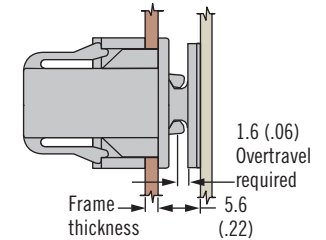

### Installation

1. Prepare frame. Snap latch into place.

2. Install spacer (if required).

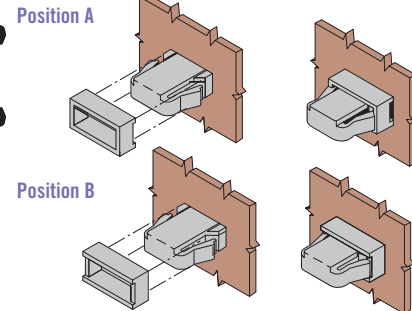
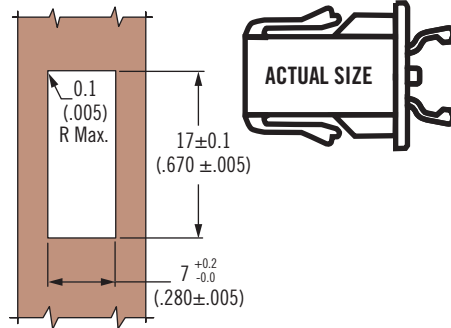

3. With alignment guide in place, engage keeper with latch. (If catch legs are retracted, push them into the latch housing to release before proceeding).

4. Peel protective backing from keeper. Close door against adhesive.

5. Remove alignment guide from keeper and discard.

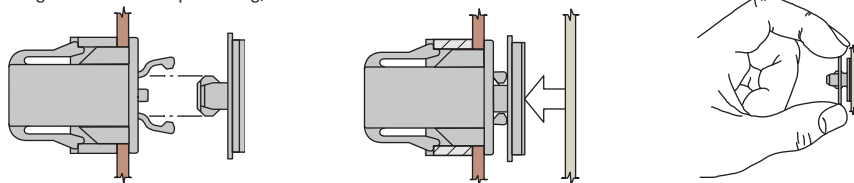

### Part Number

See table

Frame Thickness		Part Number	Spacer Position Installed	Spacer Thickness		Spacer Color
Minimum	Maximum			C	D	
0.8 (.030)	1 (.040)	E4-10-102-10	A	7.5 (.295)	6.9 (.270)	Black
1.4 (.055)	1.7 (.065)		B			
1.8 (.070)	2 (.080)	E4-10-103-10	A	6.5 (.255)	5.3 (.210)	Natural
2.9 (.115)	3.2 (.125)		B			
4.6 (.182)	4.9 (.192)	E4-10-104-10	A	3.6 (.143)	2 (.080)	Gray
6.2 (.245)	6.5 (.255)		B			
8.1 (.320)	8.6 (.340)	E4-10-101-10	Spacer not required			



## Latch

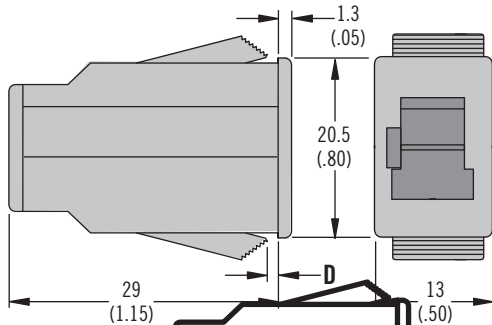

## Installation

1. Prepare frame

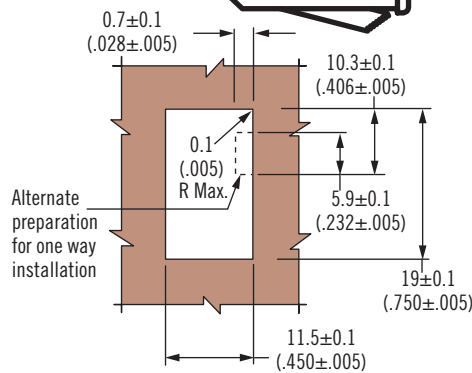

3. Re-engage keeper with latch

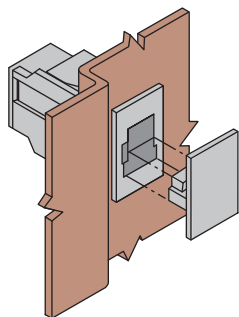

## Keeper Assembly

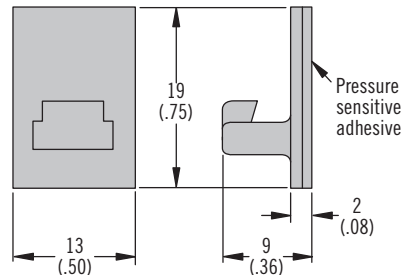

2. Snap latch into place

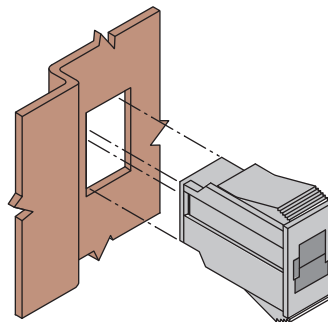

4. Peel protective backing from keeper  
Close door against adhesive

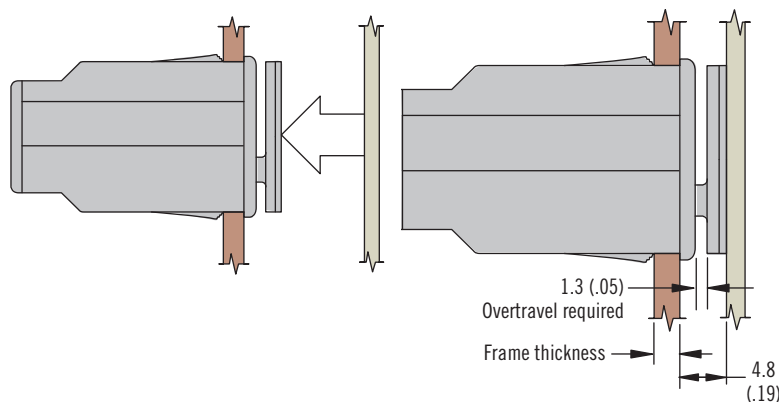

- Concealed latch points
- Door ejection feature
- Snap-in installation

## Material and Finish

Latch and keeper: Acetal, black and thermoplastic polyester, black

## Performance Details

Average tensile load:

Self-adhesive keeper: 50 N (11 lbf)

Integrally molded keeper:

120 N (27 lbf)

Operating temperature range:

-40°C (-40°F) to 105°C (220°F)

Flammability rating: UL94-HB

## Installation Notes

Be sure the mounting surface is clean and capable of retaining a satisfactory adhesive bond.

Keeper can be molded into application door

Self-adhesive keepers are designed to function under intermittent break-away loads

Frame Thickness		D	Part Number
Minimum	Maximum		
1 (.04)	3 (.12)	0.9 (.035)	E4-10-201-10
3 (.12)	5 (.20)	2.9 (.115)	E4-10-202-10
5 (.20)	7 (.28)	4.9 (.196)	E4-10-203-10